

MAS Series

Tender / Bid specifications :

Specifications for Non-Motorized Projection Screen:

- Screen Size: 153cm x 150cm to 240cm x 245cm
- Screen Gain: 1.2
- Viewing Angle: 160 degrees viewing cone
- Screen Materials: Matte White with fibreglass coating,
Flame Retardant and fungus resistant
- Construction & Design: Heavy Duty aluminium casing with powder-coating finishing
Strong tensioning device to ensure flat screen
Auto-Gear Mechanism for precise and effective stopping at desired height
Auto-Gear Mechanism to allow screen roll up smoothly and steady like a motorized screen
- Installation: Come with universal brackets for wall or ceiling mounting
Screen position can be adjusted horizontally even after installed

Dimension of MAS Series Screen

Sectional View

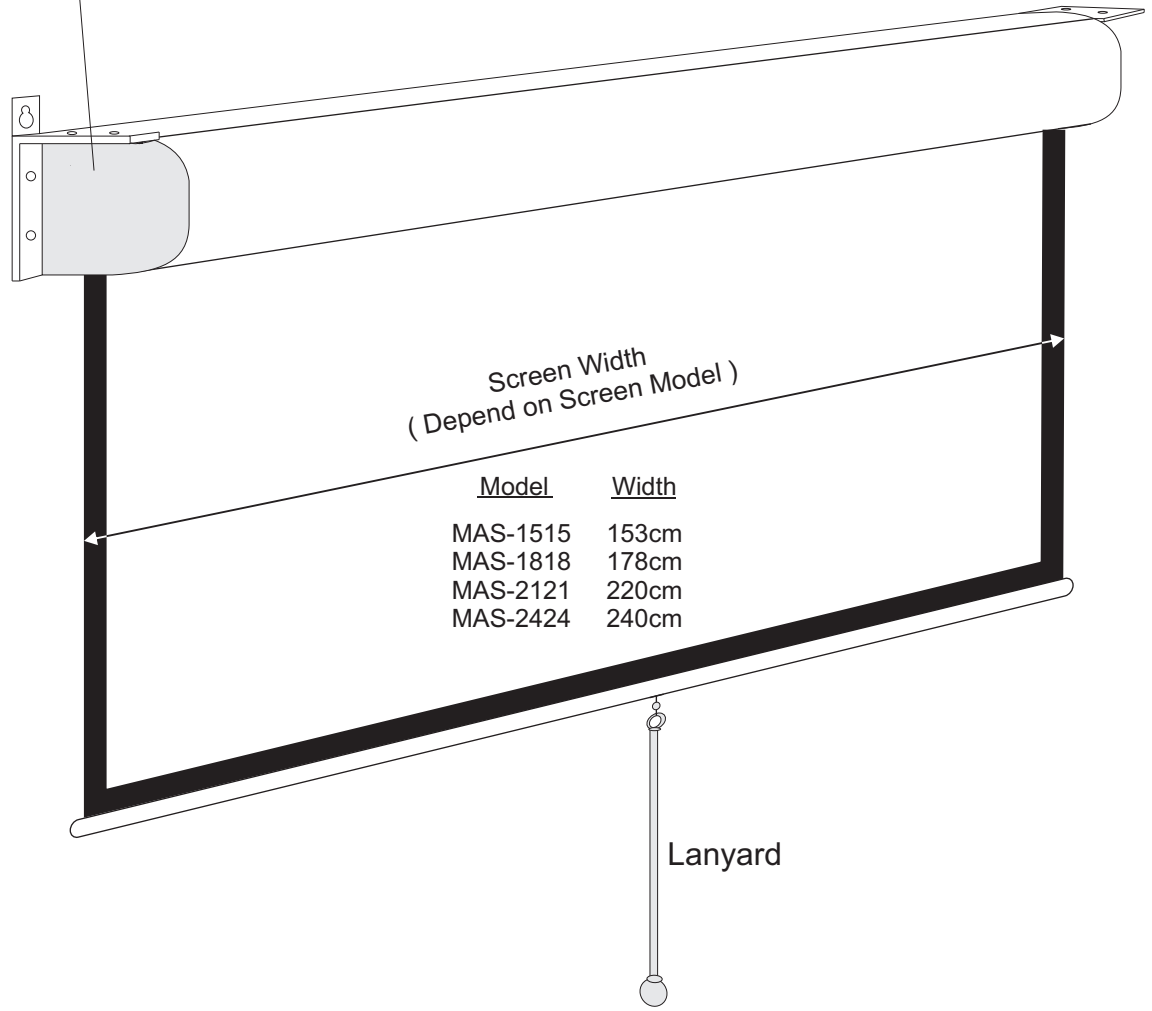
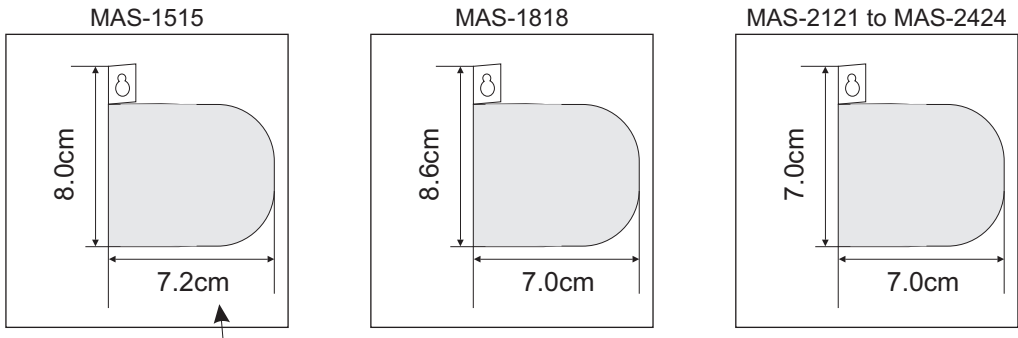

Pelmet Mounting: Recommended Pelmet Size

MAS Series (Standard Size)

Recommended Pelmet Width = Screen Casing Width + 10cm

Screen Casing Width = Screen Width + 11.0cm (MAS-1515 & MAS-1818)
 Screen Casing Width = Screen Width + 14.0cm (MAS-2121 & MAS-2424)

