



**Remaco CMS (Concealed Motorized Screen)** is an innovative concept designed with two purposes in mind. To fully conceal the entire screen casing when not in use and blend with interior design to achieve excellent aesthetic result. It is made possible by unique automatic trap-door which open when screen is lowered and vice-versa. It is made of quality screen fabric and designed for ease of operation control and installation. Screen switch used to automatically move screen down or up. The switch position will determine if the screen moves when adjusting upper or lower limits. To adjust screen limits, first gain access to the motor assembly located on the right hand side.



- ~ Fully Concealed when not in use
- ~ Suitable for all kinds of false ceiling
- ~ Compact, Light weight and Beautiful Finishing
- ~ Ease of installation
- ~ Adjustable setting kit desired up/down position
- ~ Adjustable screen position horizontally



### Screen Sizes

Model	Diagonal (Inches)	Width x Height (Inches)
<b>Standard Size</b>		
CMS-1515		62" x 62"
CMS-1818		72" x 72"
CMS-2121		84" x 84"
CMS-2424		96" x 96"
CMS-2727		108" x 108"
<b>Video Format 4:3</b>		
CMS-1310V	62"	50" x 37"
CMS-1612V	80"	64" x 48"
CMS-1814V	90"	72" x 54"
CMS-2015V	100"	80" x 60"
CMS-2217V	110"	88" x 66"
CMS-2418V	120"	96" x 72"
CMS-2721V	135"	188" x 81"
<b>HDTV Format 16:9</b>		
CMS-1609H	70"	61" x 34"
CMS-1810H	80"	70" x 39"
CMS-2011H	92"	80" x 45"
CMS-2212H	100"	87" x 49"
CMS-2414H	110"	96" x 54"
CMS-2715H	123"	107" x 60"

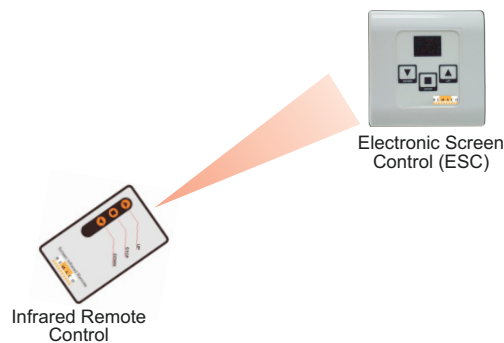

*All screens supplied are with black borders.  
Every screen is supplied with remote control,  
electronic screen control and universal brackets.*

## Specifications :

Motor Speed :	26 rpm
Operating :	120 deg. Celsius (thermostat cut off motor)
Fabric Roll Speed :	7.35 m/min (12.3 cm/sec)
Screen Gain :	1.2
Viewing Angle :	160 degrees viewing cone
Screen Materials :	Matte White with fibreglass coating, Flame Retardant and fungus resistant
External Wired Control:	Normally open, momentary contact closure (voltage free)
IR Remote Sensitivity Distance :	Maximum 15 metres
Sensor Coverage :	160 deg. (horizontal) 150deg. (vertical)
Power Consumption :	195W (with load) 10W (without load)
Current :	1.8 or 0.85 Amperes
Voltage :	100 - 120 VAC or 220 - 240 VAC, 50/60 Hz

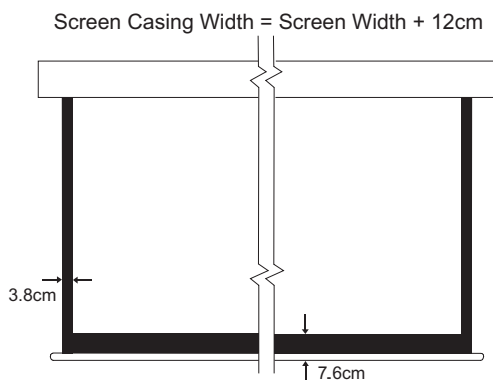

Screen with 3 sides black border

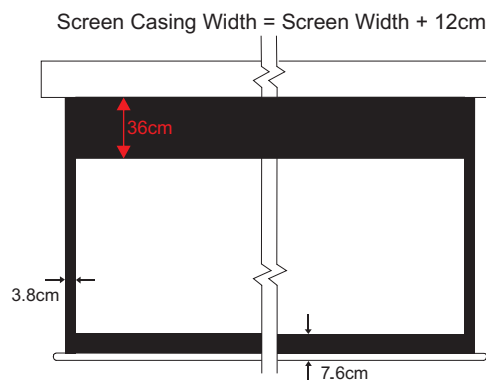

Screen with 4 sides black border

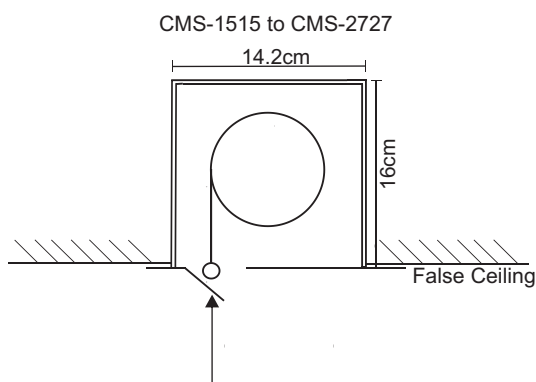

Trap Door \*

\* Trap Door is optional

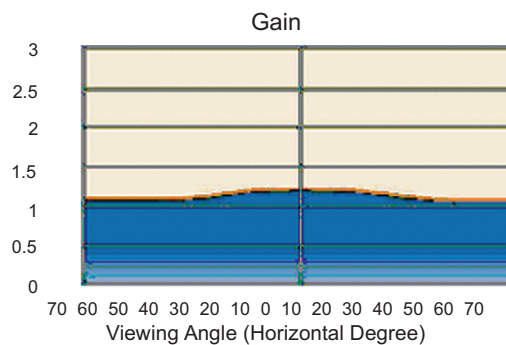

\* For details dimension ,  
please refer to technical specifications at  
[www.remacotech.com](http://www.remacotech.com)