

## Installation Guide (For BKT-551)

### Important Notes:

All Plasma / LCD TV brackets are thoroughly inspected and fully tested operational in factory. We accept no liability whatsoever for any losses due to improper operation, or any unauthorized alternation. All trademarks contained in this installation guide are the property of their respective owners.

## LCD/Plasma Screen Fixed Bracket

Model.:BKT-551

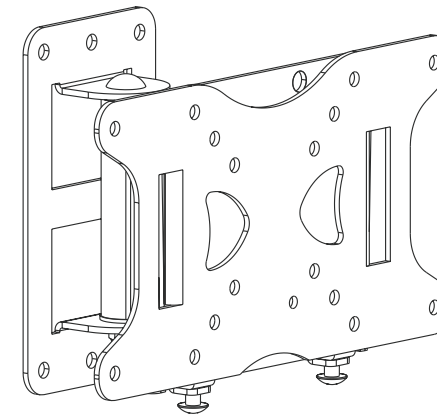

- TV Size Rang: 10" - 32"
- Universal VESA mount
- Easy to install: sliding plate operation
- Max load capacity: 15Kg/33lbs
- Adjustable Tilt: 0° - 15°  
Adjustable Roll Control: ±60°

### Step 4

Carefully position monitor so that Wall and Monitor Plates are vertically aligned, with the bottom of Monitor plate overlapping the top of the Wall Plate by approximately 1".

Gently lower monitor into position, sliding the two plates together until the Monitor Plate bottoms out. (Fig. 3)

**Caution:** Make sure that the plates are engaged on both sides of the mount before releasing grip on monitor.

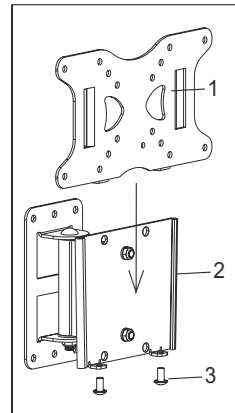

Fig 3

### Step 5

Install two Safety Bolts (3) through bottom of Wall Plate. (Fig. 3)

**Caution :** This Product LCD /Plasma Wall Mount Bracket is intended for use only with the maximum weights indicated .See apparatus instructions .Use with products heavier than the maximum weights indicated may result in instability causing possible injury .

**Parts:**

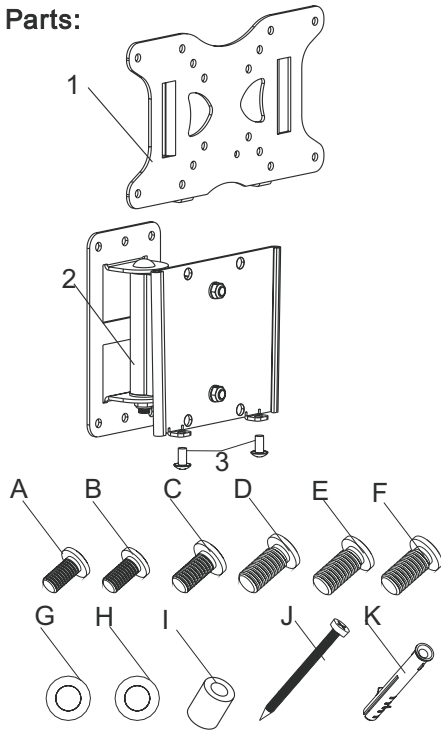

Letter	Qty	Description
1	1	Monitor Plate
2	1	Wall Plate
3	2	Safety bolt
A	4	M4X12 Screw
B	4	M4X25 Screw
C	4	M5X12 Screw
D	4	M5X25 Screw
E	4	M6X12 Screw
F	4	M6X25 Screw
G	4	M5 washer
H	8	M6 washer
I	4	9/16" spacer
J	4	Long bolt
K	4	Wall anchor

**Step 1**

Determine the desired location for the monitor.

**Important** Make sure there is adequate mounting space available for the monitor, considering the monitor dimensions. This mount is supplied with the necessary hardware for either Wooden Stud Mounting or Masonry Mounting. Determine your mounting type and proceed accordingly.

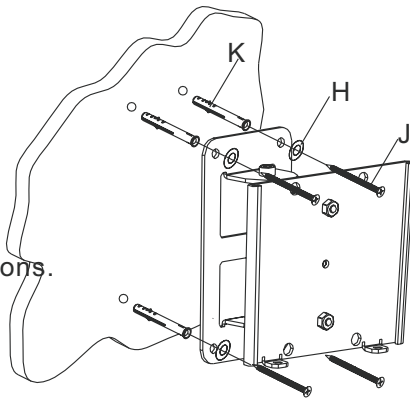

Fig 1

**Step 2**

**Wooden Stud Mounting:**

Using an electronic stud finder, locate the center of the wooden stud. Position the Wall Plate (2) in desired mounting location over stud. Level the Wall Plate with a bubble level, and then using the wall plate as a template, mark mounting hole locations over the center of the stud. Drill 2 mounting holes 50mm deep, into the stud using a 3mm drill bit.

**Masonry Mounting:**

Position the Wall Plate (2) in desired mounting location on wall. Level the Wall Plate with a bubble level, and then using the wall plate as a template, mark mounting hole locations on wall. Drill 2 mounting holes 50mm deep, using a 8mm masonry bit. Insert Wall Anchors (K) into the mounting holes, and lightly tap them flush to the wall with a hammer.

**Caution:** Wall Anchors should only be used for masonry mounting. **NEVER** use wall anchors to mount the mount to drywall. Securely mount Wall Plate with supplied Long bolt (J) and washer(H).

**Step 3**

Attach Monitor Plate to back of the monitor with 4mm, 5mm or 6mm supplied hardware. (A-F) (Fig. 2) Check the monitor's owners manual for correct length screw to use.

Some displays will require the use of an additional spacer to provide access to cable connections, or because the display has a recessed mounting area. In this case, use the long screws in pouches B, D or F, along with square (I) for each screw.

**Caution:** Never force screws into the monitor, as damage may occur.

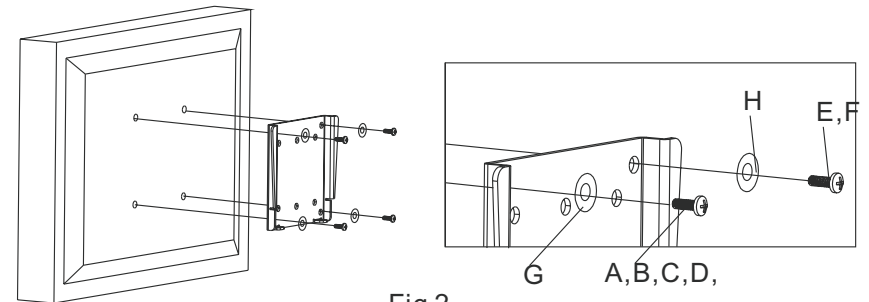

Fig 2