

Installation Guide (For BKT-M590 / BKT-M592)

BKT-M590 / M592

Important Notes:

All Plasma / LCD TV brackets are thoroughly inspected and fully tested operational in factory. We accept no liability whatsoever for any losses due to improper operation, or any unauthorized alternation. All trademarks contained in this installation guide are the property of their respective owners.

1. Application:

Remaco BKT-M590 / M592 Motorized LCD lifter is designed to lift LCD monitor. It is designed to be light-weight, artistic appearance, easy of installation. Remote controlling through integrated centralised control system is possible or using radio-frequency remote control. This product can be adjusted easily to avoid the direct light into human eye in accordance with the principle of ergonomics. In that way it can reduce eye's tiredness. This product is suitable to use in posh boardroom, premium conference room.

2. Features:

- † Motorized Lifter with soft-touch membrane.
- † Safety automatic stop to prevent injury.
- † Radio frequency remote control.
- † Automatic tilt backward in upright position.
- † Suitable for LCD monitors
- † Automatic opening and closing of the trap door.
- † RS-485 Serial Communication Control Capability.
- † Power: AC 220V, 50Hz

Models	LCD Screen Size	Maximum LCD Dimensions (Width x Height x Depth)
BKT-M590	17"	(395 x 410 x 66)
BKT-M592	19"	(435 x 410 x 66)

3. Bottom Panel:

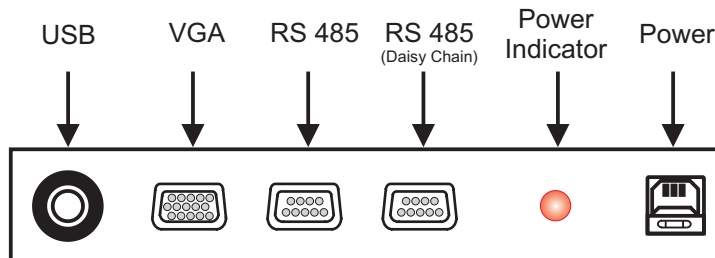

4. Soft-touch Membrane Switch:



5. Mounting:

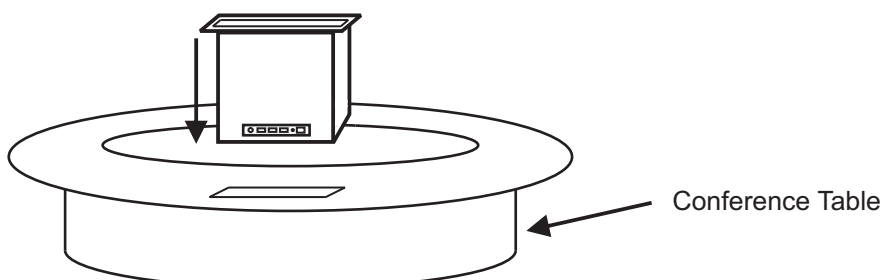

6. Methods of controls:

- a) By membrane switch located on top of the lifter
- b) Using contact closure control through rainbow cable
- c) RS 485 & RS 232 Serial Communication Control
- d) Using Radio-frequency

7. Contact Closure Control through rainbow cable

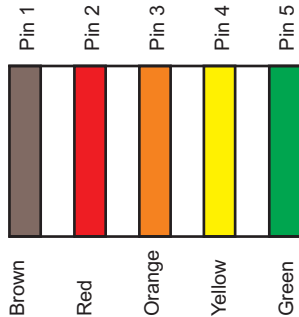

Brown = pin 1
 Red = pin 2
 Orange = pin 3
 Yellow = pin 4
 Green = pin 5

To control movement of the motorized lifter

Up=> short pin 1 & 4

Down => short pin 2 & 4

Stop => short pin 3 & 4

8. RS 485 Serial Communication:

- Install RS-485 software program into your computer
- Select "Group 1" to "Group 60" (Depend on the number of lifters are installed)
- Press "△", "□" simultaneously on membrane switch, "power indication" will blink indicates learning mode activated
- Clip "Learning" on the program window and the lifter is programmed
- Repeat above steps for the rest of lifters

9. RS-232 Serial Communication:

BKT-M Series use a protocol of 8 bits data: 2400 band, no parity, 1 stop bit.
 Data bits has to send out 4 times continuously.

Band= 2400
 Parity= none
 Stop Bit= 1

Pin	RS-232 function	Description
1	-	No connection
2	Tx	Transmit data
3	Rx	Receive data
4	-	No connection
5	Gnd	Signal ground
6,7	-	No connection
8,9	-	No connection

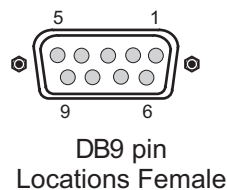

Legend For X

X = 0 means complete control

X = 1 to F mean designed group control

Control Codes (Two Digits)	Commands
AX	Log on
CX	Stop
DX	Up Position
EX	Down Position

10. Pairing of RF remote control to lifter:

- Press "△", "□" simultaneously on membrane switch until red LED "Power Indicator" at the bottom panel blink.
- Use small screwdriver press on the switch at the back of RF remote hole. If the "Power Indicator" bright steadily, both are paired.
- To reset the former controlling code press both buttons "△", "□" simultaneously on membrane switch until a "Power Indicator" blink. When red LED fully lighted, stop pressing. Press both buttons again, if "Power Indicator" lighted steadily, it means former code deleted.
- To program again, repeat above steps

11. Dimensions (mm):

Model: BKT-M590

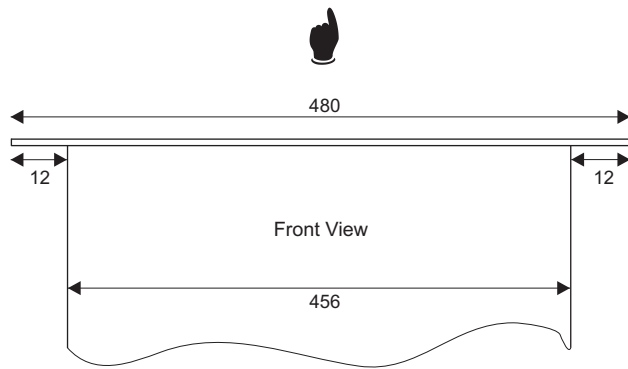
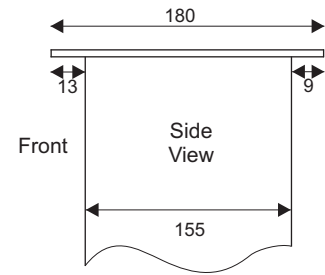
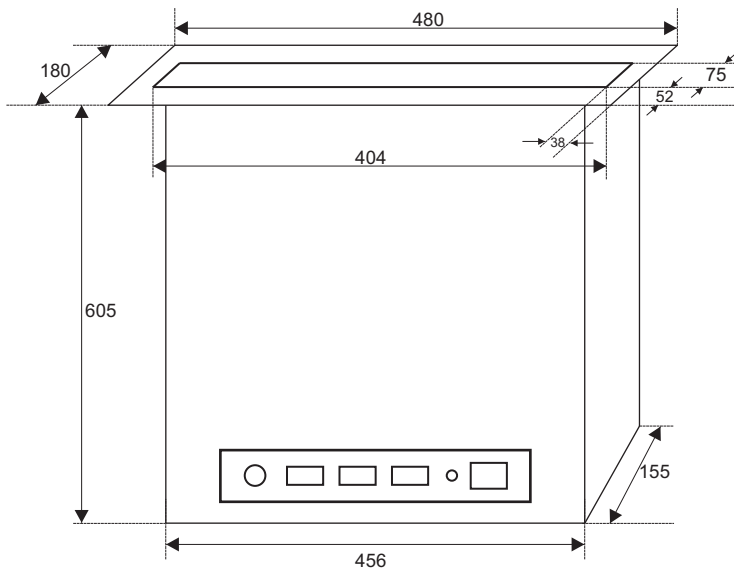

Model: BKT-M592

