

Installation Guide (For BKT-552)

BKT-552

Important Notes:

All LCD Monitor brackets are thoroughly inspected and fully tested operational in factory.
 We accept no liability whatsoever for any losses due to improper operation, or any unauthorized alternation.
 All trademarks contained in this installation guide are the property of their respective owners.

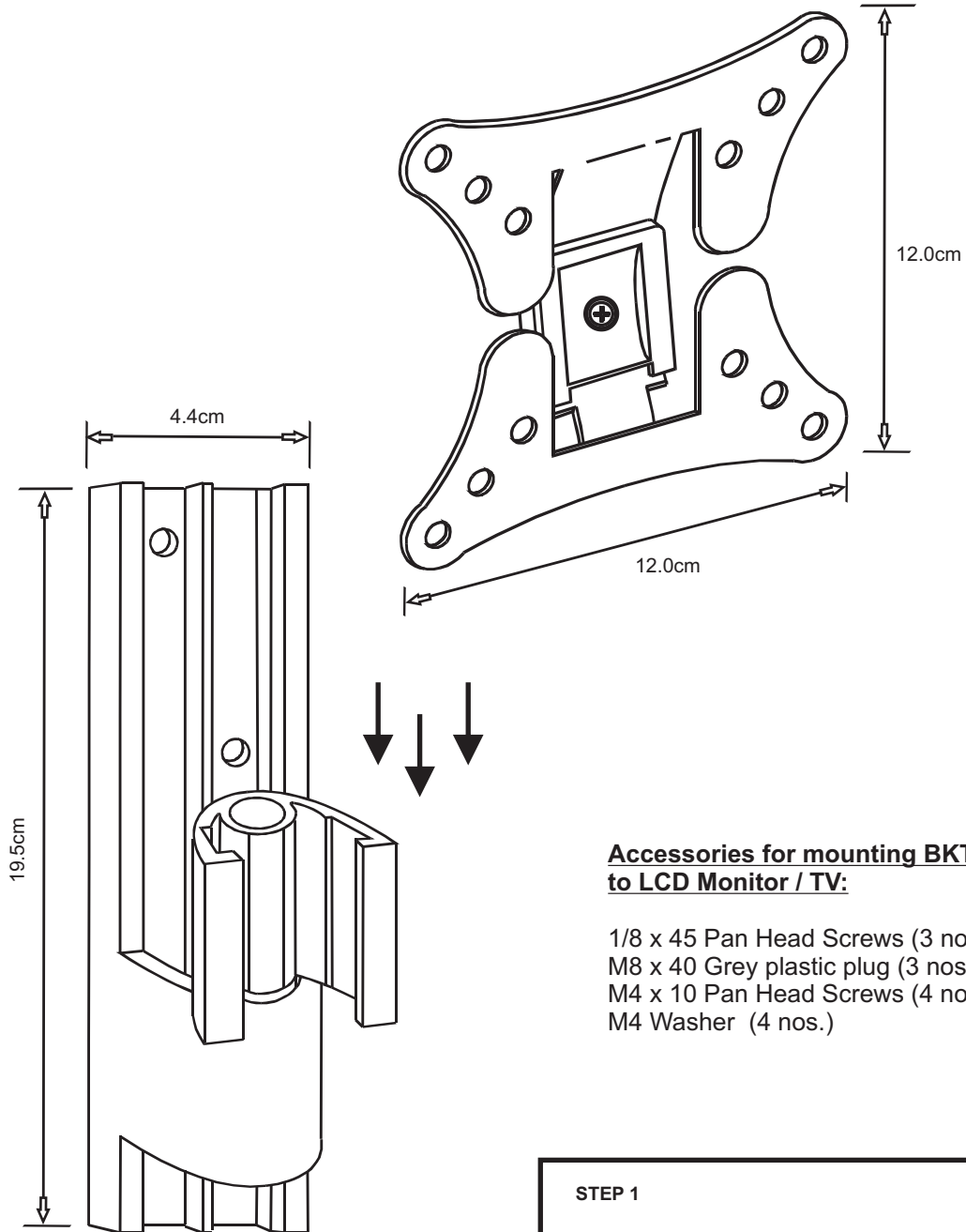

Accessories for mounting BKT-552 to LCD Monitor / TV:

- 1/8 x 45 Pan Head Screws (3 nos.)
- M8 x 40 Grey plastic plug (3 nos.)
- M4 x 10 Pan Head Screws (4 nos.)
- M4 Washer (4 nos.)

STEP 1

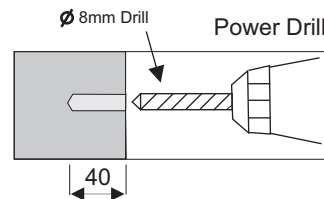

A) Drill Dia 8mm Holes to a depth 40mm.
 (Note: Do not drill too deep)